

Use of auxiliary channels for impedance analysis: Detecting failure mechanisms within a fuel cell / battery stack

John Harper and Brian Sayers
Solartron Analytical, Farnborough, UK.

TB/ANALYTICAL/002

Introduction

The introduction of the Solartron CellTest® System heralds a new era in high performance DC and impedance testing for energy storage devices such as batteries, fuel cells and supercapacitors. Its innovative design provides measurements that are beyond the capabilities of other multi-channel test stations. In this application note, we describe one such feature that allows the COMPLETE characterization of a multi-cell battery. These techniques can be applied to the investigation of any multi-cell energy storage device.

A fuel cell stack or multi-cell battery is a complicated system and it is possible that failures can occur on any of the individual cells within the system. Single channel impedance analyzers typically connect across the end terminals of the entire stack and therefore measure the total impedance of the stack. Whilst this is useful for assessing the overall performance of the complete stack, it cannot provide information regarding the location and cause of faults in individual cells. The Solartron CellTest System with the 14702 auxiliary voltage measurement option fitted, has been specifically designed to provide impedance measurements from individual cells within the stack, allowing rapid assessment of the behaviour of each cell.

Experimental

Figure 1 illustrates the connections from the 1470E to the test device. In this example, four 1.5V AA batteries are connected in series. The main impedance channel is connected across the end terminals of the stack – this provides measurements of the impedance of the entire stack. Four auxiliary voltage measurement channels are connected across individual cells within the stack to provide impedance measurements of each separate cell.

From the resulting impedance measurement data, five complex plane plots are shown overlaid in figure 2; four traces are from the auxiliary channels and one is from the main channel. One can see clearly that the combined impedance of the stack is in the order of 1.5ohms. Clearly this is very high and suggests that a problem occurred somewhere in the stack (indeed one cell had been deliberately discharged prior to the measurement). The overall impedance measurement cannot reveal on which cell the failure occurred and more importantly, cannot give any diagnostic information regarding the mode of failure. The ability of the CellTest System to measure the impedance of individual cells enabled, in this experiment, detailed diagnostic information to be obtained from each cell and the impedance results from auxiliary channel three immediately revealed that the third cell had indeed suffered a catastrophic failure and was essentially behaving like a resistor.

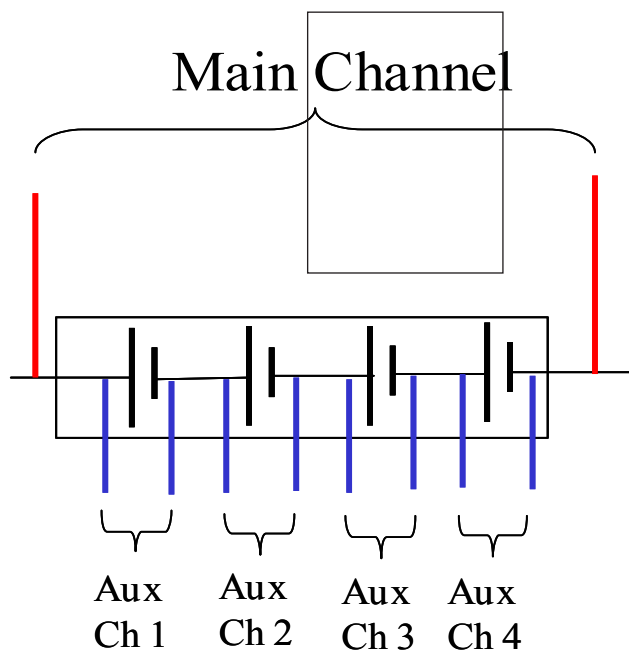

Figure 1 : Connections from the Solarton CellTest System to the test device, main channel across the whole cell, auxiliary channels across individual cells

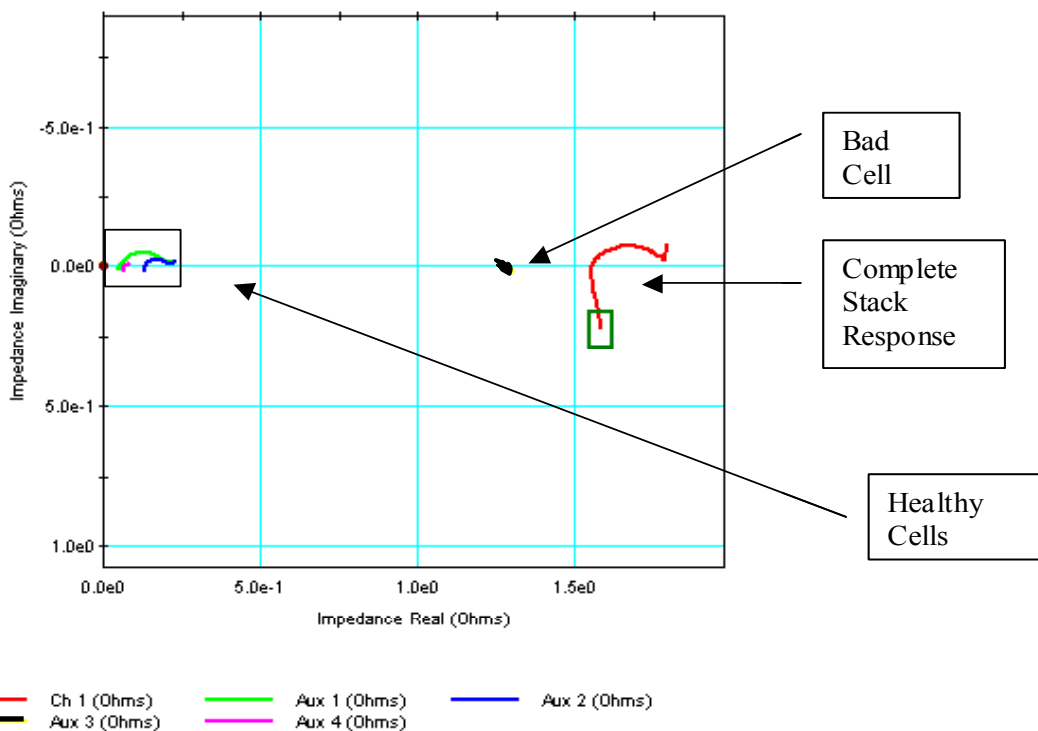

Figure 2: Complex plane plots of entire stack (red curve) and individual cells. FRA settings: single sine correlation with 1 second integration, AC stimulus = 20mA

Conclusions

Simultaneous high speed impedance measurements of individual cells within a fuel cell stack or battery are now possible with the Solarton CellTest System. This allows the engineer or scientist to identify where a problem occurred within the stack and in addition, to diagnose the probable mode of failure.